

REEFIT

www.almasts.com.au

+61 3 6331 3171

REEFIT SYSTEM B

Installation Guide

Manufactured By Almasts Australia Pty Ltd

Unit

Serial Number

Date

Some images may depict generic parts. Precise details may vary from those depicted.

Quick start guide

If you don't read anything else in these instructions please read this page

- Naturally, we recommend that that you read the instruction manual thoroughly. Naturally, many of you won't, so we've included some brief notes here to help you avoid the worst pitfalls.
- If you are going to tackle the installation of the system, we really recommend familiarising yourself with the components by looking at the *Recognising the system parts* section on page 4
- You can use an existing stay or a new stay; both are explained on page 6
- Stays for furlers (any furlers) *must* have a toggle or articulating fitting at both the top and the bottom.
- ***DO NOT install the furler base pin through the chainplate itself. Attachment of the stay to the chainplate must always be made with a toggle assembly for articulation.*** We will not warrant any failure if the base pin is fitted directly to the chainplate, as it will reduce the ability of the forestay to articulate.
- To make your life easier, there is a list of the tools you might need for assembly on page 7.
- The actual *assembly* of the unit is simple and is covered in only four pages, starting on page 8, and we really recommend that you read those too. We have eliminated any calculations, so you only need to be able to measure to 120mm to complete the assembly.
- Page 15 has information and measurements for your sailmaker. Copy it or tear it out and give to him, along with the foil sample that's in the kit. ***The UV strip must be on the starboard side.***
- The post-installation checklist on page 13 is most important. You ***must*** check off ***all*** the points covered in it before putting your sail up.
- If you don't put the deflector block on you will probably have problems when furling. Very few normal mastheads are configured to readily suit the requirements of furlers and halyard wrap is the most common problem world-wide. We think it's critically important to eliminate it, that's why we supply a special block to do it. Info about positioning and installing the block is on page 12.
- Watch out for other halyards near the furler both at top and bottom. They will get hooked up inside the sail when you start to furl unless you make sure that they are stored so that they can't. If you hook one up, you won't be able to furl the sail.
- ***We won't cover damage caused by power winching under the warranty. See why on page 14.***
- Page 16 has a troubleshooting guide so you can resolve the problems caused by not reading the instructions in the first place. We are happy to give advice and help you with any problems, but we'd prefer that you go through the troubleshooting guide prior to calling for assistance.
- Keep the instruction manual on the boat when installation is complete. The unit serial number and details are on the front, and the warranty registration slip is in the back to be filled in and returned.

Contents

Quick start guide.....	2
Contents	3
General Overview.....	3
Recognising the system parts	4
Recognising the system parts (2)	5
Using a new stay	6
Using an existing stay	6
Tool list	7
Assembly of the foil	8
Fitting the parts.....	10
Using the furler	14
Maintenance	14
Sails.....	15
Troubleshooting.....	16
Race Pack Option Information	17
Parts List.....	18
Warranty and Contact Details	19

General Overview

The Reefit Headsail Furler









The Reefit Headsail Furler is a *Sail Reefing System*. This means it is purpose designed not only to roll away and store your headsail when not in use, but also to allow you to sail with the sail partly or fully unrolled. You are able to adjust the sail area presented to the wind dependant on the conditions, and the independent tack and head swivels will ensure that the sail is shaped as it furls to maintain the best sail shape regardless of the amount you reef.

Reefit has been manufactured to the highest standards to ensure trouble free use throughout its life with minimal maintenance.









It is with great pleasure that we are able to supply a fully Australian designed, manufactured and assembled furling system that performs above industry standards. We have put a lot of effort into the functionality, life, and features of the system, and have been manufacturing our own and repairing all brands of furlers for 25 years, giving us extensive practical experience.

Our Reefit Headsail Furlers have been designed to be easily installed by yacht owners. For the most convenient installation, remove the forestay from the boat and assemble the furler on a clean level surface, whilst protecting the system and components from any damage during assembly, especially if the surface is concrete.

Recognising the system parts

<p>Drum / Torque tube assembly This is the main component in the box. Drum, rope guide, tack swivel, and torque tube.</p>	
<p>Top swivel unit The long swivel goes to the top. (Halyard) The short swivel goes to the bottom. (Sail head)</p>	
<p>Shroud spinner This snaps together over the stay wire.</p>	
<p>Deflector block Bend the feet to suit your mast shape. 4 fasteners to install.</p>	
<p>Top foil bearing assembly (1 only required) The bearing has one large diameter end. The carrier has no holes.</p>	
<p>Foil joint assembly (1 set for each join) The carriers have 4 holes drilled and tapped. The bearing halves are symmetrical at both ends.</p>	
<p>Bottom foil bearing (Supplied pre-installed in the sail entry foil) Remove and re-fit during installation</p>	
<p>Sail entry foil (This is the last foil to be installed) Milled tracks at the bottom allow the sail to feed in</p>	

Recognising the system parts (2)

<p>Plain Foils These have 2 holes at each end. No sailtrack cutaways. One may need to be cut for top foil.</p>	
<p>Wire Clamp This clamps on the stay below the bottom foil bearing.</p>	
<p>Standard toggle and link Collets, nuts, and extra base pin also shown.</p>	
<p>Sail Feeder Tie on to torque tube when raising sail. Remove once sail is up.</p>	
<p>Foil Sample Boltrope size sample for your sailmaker.</p>	
<p>Instructions and Warranty</p>	
<p>Optional extension link (Only supplied if you specifically ordered it)</p>	
<p>Sail entry feeder Pre-installed in sail entry foil. Remove and re-fit during system assembly. Can be removed after sail hoisting to reduce chafe.</p>	

Please check that you have all parts before disposing of system packaging.

Using a new stay

Though the Reefit systems are designed to fit to existing stays, you may prefer to renew your forestay at the same time. For new stays that are to be fitted with Reefit systems you will need to take into account our standard link. **Your original measurement from bow chainplate to stay attachment on mast should not change.** Simply incorporate the standard link / toggle (80mm) into the new stay as per the diagram below. If you have purchased a *long link* to raise your drum, this will need to be incorporated into the length as well.

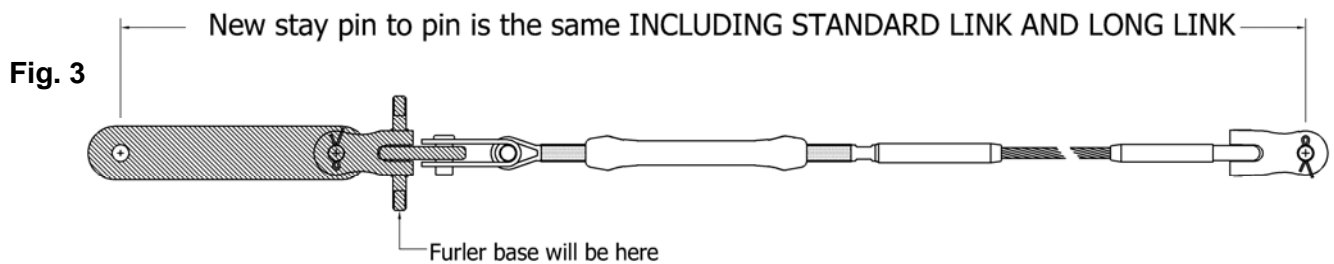
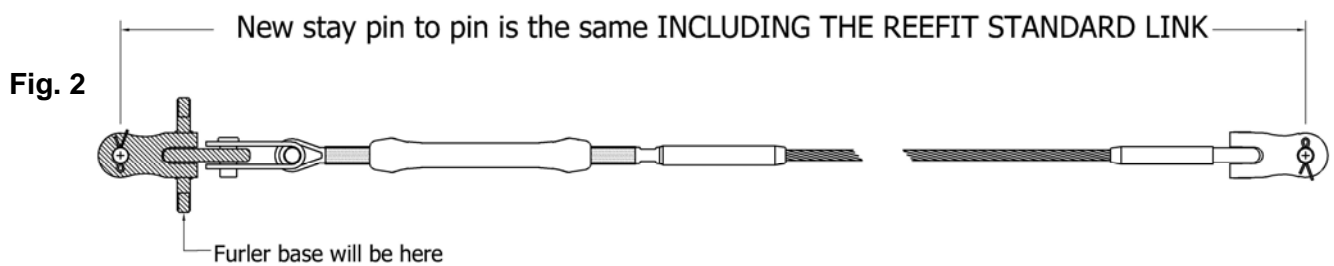
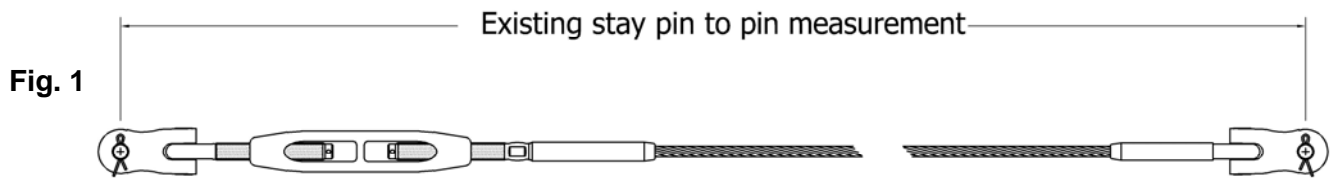

- The standard link supplied with each Reefit B measures **80mm pin to pin**.
- Long links are available in 100mm and 200mm lengths. **These are an optional extra.**
- The new swage fittings at top and bottom **MUST** terminate in toggle style fittings for articulation in all directions. **DO NOT attempt to bypass this requirement, as it will most likely result in forestay failure.**

Using an existing stay

Reefit systems are designed to fit to existing stays.

Mark or tape the rigging screw on your stay before removal so you will be able to reset the original length when it is off the boat. **Your original pin to pin measurement, from the bow chainplate hole to the stay attachment point on the mast, does not change. (Refer to Fig. 1 above)** Simply incorporate the Reefit standard link / toggle into the stay length by taking up an additional 80mm adjustment in the rigging screw from its original setting. You are aiming to achieve the same result as in Fig. 2, but by taking up on your existing rigging screw, rather than modifying the stay. You should not be overly concerned if you cannot absorb the full 80mm required to achieve the original stay length measurement. An addition of up to 40mm in forestay length will not result in a noticeable difference in the helm or performance of your boat. It requires a substantial change in mast rake to produce a change in the helm characteristics.

Any additional length in the forestay will require that you take up the backstay adjustment by a similar amount, and for rigs with swept-back spreaders you will also have to tighten the cap shrouds. Please contact us if you have any queries regarding this. As professional riggers with 25 years experience, we can assure you that it is common practice to apply additional tension to the forestay through backstay adjustment, or cap shroud on swept-back rigs, and can offer you expert advice.

If you are still concerned, there are 2 options. Either will allow installation of the furler onto your existing stay

1. Use the additional base pin (pictured in the ID images), to replace the swivel pin in the toggle of your rigging screw. This will require removing the existing pin (in most cases by drilling it out), and replacing it with the extra base pin we've provided. Detailed instructions for this option are available on our website, or by email from us. **DO NOT install the furler base pin through the chainplate itself. Attachment of the stay to the chainplate must always be made with a toggle assembly for articulation.** We will not warrant any failure if the base pin is fitted directly to the chainplate, as it will reduce the ability of the forestay to articulate.
2. Have the forestay shortened and re-swaged. Most rigging fittings are manufactured so that this can be done economically, so that if you run out of adjustment in your rigging screw, the new fitting will overlap so that you get back the full range of adjustment again, without needing to replace the entire rigging screw.

If you have purchased a *long link* to raise your drum, the stay will definitely need to be shortened to incorporate both the *long link* and the *standard link*.

PLEASE NOTE:

- ***It is essential that stays to be fitted with a Reefit, or any reefing system, have a toggle or similar articulating fitting at the top, and that it and the bottom toggle are free to move.***
- ***Don't squeeze or jam the toggle or link plates into the masthead or bow fitting as they can bind up, preventing movement and possibly causing forestay failure. They must fit easily and articulate easily so they can follow the movements of the forestay both fore & aft, and athwartships.***

Tool list

The following readily available tools will simplify owner installation.

- 3m Measuring tape
- Hacksaw to trim top foil to length
- Electrical or 'Gaffer' tape
- Pencil or felt-tipped marker.
- Adjustable spanners x 2 for adjusting rigging.
- Socket with ratchet handle to tighten base pin nuts. (A spanner will work, a socket is easier)
- Pliers for opening / closing split pins in rigging.
- Hammer & punch sometimes needed to remove forestay pin from masthead.
- Bosuns chair for going aloft.
- Cordless drill, 3/16" drill bit (5mm) and 1/4" BSW taper tap to install deflector block.
- Phillips screwdriver # 3 or # 2 to install deflector block.

Allen key, Loctite, nuts, and fasteners are included with the furler kit.

Assembly of the foil

Lay the forestay out on a clean level surface sufficient for the work. If necessary, the assembled furler can be carried by 2 or 3 people (it's not heavy, just floppy) so the best location is not necessarily right at the boat. If you're on a concrete surface you will need to protect the components against abrasion.

Strip the rigging screw parts off the stay, to leave only the swaged threaded stud at the bottom (swaged to the forestay wire).

Lay the foils out end to end alongside the wire, starting from the bottom with the sail entry foil, which should be level with the bottom swage fitting. **(Image 1)**

The total length of all foils end to end must be 120mm less than the length of wire between the swage terminals. One plain foil may need to be cut to length. **(Image 2)** This will become the top foil.

NOTE... If the cut foil is going to be shorter than 260mm then don't cut it yet. You will need to cut 500mm off the next foil down. This will move the top joint 500mm further down the stay, ensuring the top bearing and top joint are not in conflict with each other. Remember to add the 500mm to the original measurement at which you were going to cut the top foil before making the cut. This also means the fastener holes will need to be re-drilled in the cut foil. Hole centres are 20mm and 70mm down from the end of the foil. Hole size is 21/64" (8.4mm). Drill a pilot hole first. Remove the burrs from the holes and in the sailtracks.

Locate the shroud spinner in the kit. It fits at the top of the wire, under the top swage fitting **(Image 3)**. Mate the two halves over the wire and snap them together as pictured.

Assemble the top foil bearing and carrier onto the stay near the upper swage fitting **(Image 4)**.

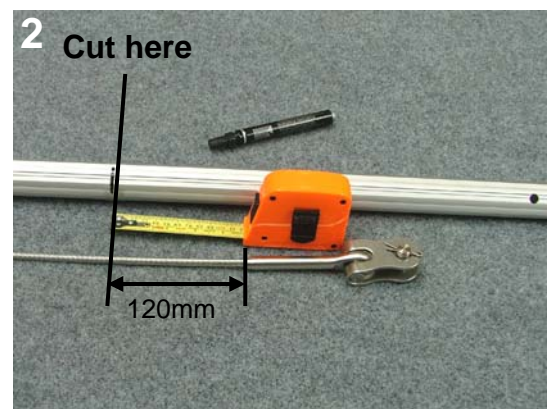
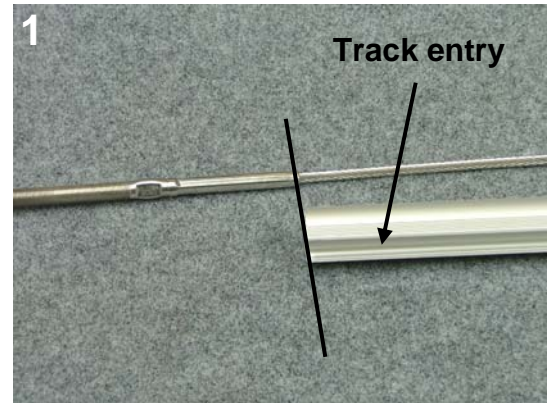

Select the foil that you cut to length first. With the end that you cut towards the top, slide it on to the stay over the bottom swage fitting and up to the top where you can engage the top foil bearing assembly. **(Image 5)**



Push the top bearing assembly home into the foil. **(Image 6)**



Select a joint connector and bearing. **(Image 7)** Lay the connector down with its the slot facing up, and one half of the bearing laid in the bottom of it with the wire groove facing up. Position the wire so it lays through the connector, in the groove of the bearing. Align the other bearing half at one end of the connector, and then slide it in lengthways.

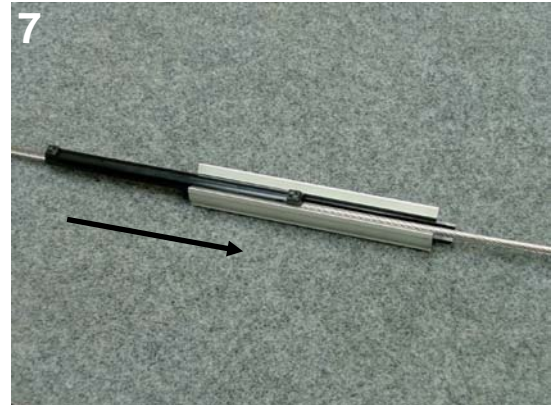

Rotate the nylon bearing inside the connector until the end lugs of the bearing face across the connector, then fit the assembly into the lower end of the top foil, and slide in until the threaded connector holes align with the drilled holes in the foil. Apply Loctite 243 (supplied) to the thread in the connector and use the supplied Hex key to screw one cap screw in loosely to hold the connector in place. **(Image 8)** *You will find the cap screws easier to handle if you put them on the end of the hex key.* Fit a second cap screw in the same manner. Bring the next foil section up the wire, engage the connector, and align the holes before fastening as before.



Fitting the parts

Connect all foil sections together in this manner with the sail entry foil at the very bottom. Ensure that all screws are tight and Loctited in place as they will cause catch points for the swivel unit when hoisting or lowering sail, should they become loose. **(Image 9)**



Dismantle and remove the bottom bearing assembly from the bottom of the sail entry foil, noting how it will go back together.

Unscrew and remove the sail entry feeder from the entry foil (*the fasteners remain partly screwed in to the feeder*). You can then fit the swivel unit onto the foils with the shorter halyard swivel to the bottom. **(Image 10)** Test all joints by sliding the swivel unit all the way to the top of the foil and back down again.

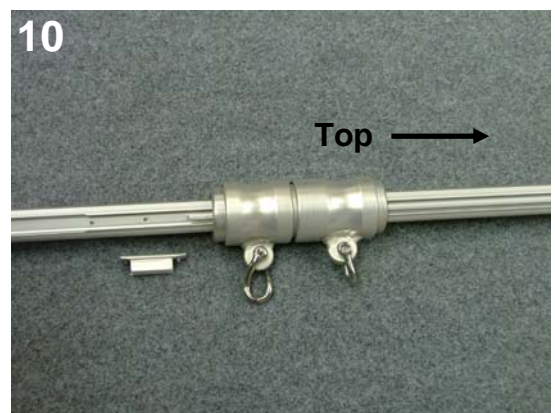

The sail entry feeder can now be refitted in the bottom foil below the swivel unit.

Slip the torque tube / drum assembly onto the stay, and align the drive lug with the milled track of the entry foil. **(Arrowed Image 11)** Slide the drum assembly up to the top of the entry foil cutout. (It stops at the sailtrack feeder)



Now you can re-assemble the bottom bearing and support sleeve over the wire and fit it back into the bottom of the entry foil. **(Image 12)** Loctite the cap screw into the carrier now.



Fit the forestay clamp loosely on the wire above the bottom swage fitting. **(Image 13)** This will be adjusted again when the unit is on the boat.



Use some tape to temporarily hold the torque tube onto the foil or stay whilst it is reinstalled back onto boat. **(Image 14)**



Reassemble the rigging screw and install the standard link at the bottom **(Image 15)**. If using an extended link, this should be fitted below the standard link. Leave the rigging screw adjustment open at this stage, until the system has been fitted to the boat.



Illustrated here for clarity, **Image 16** shows the fitment of the drum assembly onto the base pin. **(Normally after the furler has been fitted to the boat)** The nyloc nuts are tightened securely, pushing the collets home against the shoulders of the base pin, and holding the drum assembly firmly in position. Sufficient clearance is designed in so that the toggle will still fully articulate even when the collets are bolted up tight.



Installing on the Boat

Attach a spare halyard or line to hoist the furler up the mast. It is usually best to lift the lower end over the searails first, and then attach the top end of the stay to the mast.

Next attach the bottom toggle to the bow chainplate. Adjust forestay tension and mast rake to your satisfaction, ensuring that at least the safe working amount of thread is engaged. A tight forestay is important, as it will make the furler easier to use. If you are happy with the rig tension and rake, lock the locknuts or pins securely on the rigging screw, then lift the foil assembly up the stay until you feel it bump against the shroud spinner at the top. The bottom clamp is clamped securely on the stay wire 10mm beneath the bottom bearing. Check that the foil can move up and down by 10mm only, and then let it sit on the wire clamp and rotate it to make sure all is smooth. This provides a low-friction stop to hold the foil in place, and ensures that it cannot drop and jam on the bottom swage fitting.

Remove the adhesive tape and lower the drum assembly to fit onto the base pin. The threads on the base pin should protrude from the circular cutouts in the sides of the stainless steel drum centre tube. Insert the collets tapered end in, and fit and tighten the nyloc nuts on the ends of the base pin. **(Image 16 & 17)** Tighten nuts securely.



Hoist the halyard swivel to the top of the foil. *(Tie the halyard tail on so you can be sure to get it back down)*. This will allow accurate positioning and fitting of the halyard deflector block. Shape the deflector block base to suit the mast before going aloft to fit it over the headsail halyard to deflect the halyard.

The sheave in the block is made from high load engineering plastic, and is suitable for both wire and rope halyards. Four roundhead metal thread screws are provided and we recommend that you drill 3/16", and tap 1/4" BSW to fit them.

The halyard must **not** be parallel to the forestay. Use the block to deflect it so the halyard is vertical from the masthead down to the block, then angling out to intersect with the forestay at approx 15 degrees to the stay **(Image 18)**.



Leaving the minimum amount of halyard exposed below the deflector at full hoist allows for some stretch in the headsail luff, but as can be seen **(Image 19)**, makes it physically impossible for the halyard to wrap when furling. Measure the available luff length (between tack and head shackle bearing surfaces) whilst a man is aloft to ensure that the swivel will not foul on the masthead or halyards.

Image 18 also shows the top of the headsail well clear of the spinnaker halyard, so there is no possibility of a foul-up while furling. Contrast this with **Image 19** (same boat) where there is a chance of the headsail hooking up the spinnaker halyard when furling and causing a jam. This problem is the most frequent cause of furling problems and you should flip your spare halyards behind the cap shrouds and anchor the bottom ends at the side chainplates to minimise the risk. **(As in Image 18)**



Tie an 8mm reefing line through the round hole in the bottom drum plate with a thumb knot. You will need approximately 1.7 x the boat LOA for a reefing line, but this varies with sailcloth weight, and foot length of the sail. Try out the reefing line length with a spare line if desired. **Spool the rope on by turning the drum clockwise**, whilst guiding the rope in to form a firm and neatly stacked roll on the drum. The reefing line must enter the drum through the rectangle formed by the stainless steel crossbars on the rope guide. The rope guide position can be easily rotated to suit your deck layout to allow the line to feed on and off without friction. The sail will furl more tightly in heavier breezes. **Do not cut off excess furling line unless the sail is unfurled, and there are at least 3 turns of rope still on the drum.**

Use a forward block attached to the stanchion, pulpit, or deck to lead the reefing line off the drum. The furling line must exit the drum perpendicular to the angle of the forestay, which **requires careful placement of the forward block**. Stanchion bases can be used for other leads on deck but blocks or fairleads will avoid excess friction and give better results. The reefing line should be easily accessible in the cockpit and lead to a convenient position and a cleat. The sail is fitted after the rope is on the drum.

We find that most owners prefer to have the furling line run on the port side of the boat, but it may run on either side so long as it feeds onto the drum when the furler is turning clockwise.

The sail feeder supplied is fitted as shown (**Image 20**) with a rolling or clove hitch. We suggest that you remove it and store it safely after the sail has been raised. The sailtrack entry feeder can also be removed if desired once the sail is on. This prevents chafe on the rolled sail.

Both feeders are only required for short-handed sail hoisting, and they are not necessary when dropping the sail, nor essential for raising provided a crewmember is available to position the luff of the sail for easy feeding into the track. If you change sails regularly when shorthanded, we suggest that you leave the sailtrack entry feeder in position, and attach the prefeeder to the deck or chainplate so it is readily available but not causing chafe or wear.

Congratulations, you have completed the assembly. Please work through the post-assembly checklist below to ensure the integrity and functionality of your installation.



Post - Install checks (before sail hoisting)

	All rigging locknuts tight, pins opened etc. Check everything.
	Wire clamp on forestay lifted and clamped securely on stay. (10mm end float for foil)
	Furler base pin NOT in boat chainplate. Base pin locknuts and collets tight & secure.
	Rope guard entry aligned with furling line and secured on furler. (Grub screws tight)
	Furling line through guard opening and neat and tightly wound on drum.
	Deflector block fitted on mast and over headsail halyard.
	Other halyards clear of furler at top and bottom.
	Sail feeder tied on ready for use, and sailtrack feeder in position.
	Forestay has articulating fittings at top and bottom. (Fore & aft plane and athwartships)

Using the furler

Attach your sheets to the clew of the sail. Connect the halyard to the top swivel of the swivel unit.

Set the halyard so the swivel is about 0.8m up the foil from the sailtrack feeder. Feed the boltrope through both feeders and into the starboard sailtrack. Shackle the head of the sail to the halyard swivel at the bottom of the swivel unit. Hoist the sail and shackle the tack to the tack swivel at the top of the furling drum. The boltrope should not be in the sailtrack feeder when the sail is fully up. The halyard swivel should not be touching the deflector block at the top of the mast. Apply tension to the sail luff with the halyard and ensure that the halyard swivel is near to the deflector block but not touching it even when fully loaded. Ease the halyard to normal luff tension. It's handy to mark the halyard and deck or mast with a waterproof marker at the full hoist position.

Pull the furling line until the sail is furled and has several turns of sheet around it too.

When leaving the boat it is important to secure the furler properly. Re-furl the sail if necessary to get a tight, even furl with a minimum of 3 turns of sheet rolled around it. Cleat the furling line securely on a horn cleat or similar. Make sure that both headsail sheets are lightly tensioned and cleated off. In windy conditions poorly secured furlers can come undone, flogging the sail to destruction and potentially causing plenty of other damage.

The reefer should rarely need to be winched. The boat should be luffed, and/or the sheet eased so that the reefing can be done by hand. Once the desired sail size is achieved, the reefing line is made fast, and the sail re-sheeted. Winching on electric or hydraulic winches requires extra attention. The abundance of power and lack of physical effort required means that if the furler snags another halyard, for example, often the first you will know about it is when something breaks. **We will not cover damage sustained by power winching under the warranty.**

This unit is designed for sailing with the sail partly reefed. Deploy the exact amount of sail to suit the prevailing conditions, and the furler will easily handle normal sailing loads. You may wish to increase the convenience of the furling system, by marking the foot of your headsail at say 1.5m intervals, and marking your sheet lead position on deck to correspond. This will allow you to easily match your sail size and sheeting position to get the optimum performance from your sail. Many owners set up genoa car hauling tackles running back to the cockpit to make adjusting even easier when shorthanded. We can supply gear and advice to help you with this.

Maintenance

The furler is designed to give you years of trouble free low friction performance. When filling your water tanks, we recommend you squirt fresh water into the tack swivel and into the top of the torque tube (down the sail entry cut-out). Rotate the furler a little back and forth by hand while flushing it through. This will dislodge any salt build-up around the balls and reward you with extended life and enhanced performance from the unit. The halyard swivel unit is unlikely to suffer much salt build-up due to its height and will be flushed by rainwater; however an occasional squirt will dislodge any build-up of airborne dust and dirt.

The ball bearing material has been carefully chosen to minimise any tendency for debris to stick to the balls. The ball races **must not** be lubricated / greased / WD40 / CRC, etc as this will trap and hold grit. The use of petroleum-based products may adversely affect the balls. If the system seems tight, flush it with fresh water as above, and look for other sources of friction like dragging sheets, friction in the furling line on deck (furry / old line creates an amazing amount of friction in deck gear), or snagging other halyards at the masthead.

Adjusting the forestay or disconnecting it for travel-lift etc, only requires removing the 2 nyloc nuts from the base pin at the bottom of the furler. Remove the 2 collets and carefully slide the drum assembly up the foil, exposing the rigging screw for your work. Tape the drum assembly in the up position for your personal safety while working underneath.

Reassembly is simply a reversal of this procedure, making sure that you have locked the rigging screw and pins before you slide the drum assembly down and refit the collets and nuts. Lubricate the nuts to prevent galling. Fasten securely.

When the time comes to renew the forestay, you can either dismantle the furler and reassemble on the new stay or a new wire can be passed through the furler while it's still assembled, and the second end swaged on after provided the furler can be got to the rigging press. Contact us for instructions before you tackle this method.

Sails

Ideally the assembled furler should be measured by the sailmaker, once it has been fitted on the boat. If this is not possible, the luff length should be measured with the tape hauled up on the head swivel. Position the swivel unit at the masthead and make sure that shackles or halyard eyes are not riding on the halyard deflector block. Measure the luff between the tack and head shackles. The boltrope should end 0.75 metres below the head of the sail and above the sailtrack feeder at the tack, to ensure that the boltrope is not in the feeder when the sail is up. This will also allow the independent tack and head swivels to work. There is a spar sample supplied in the kit to enable the sailmaker to determine the correct boltrope or luff tape to be used. Webbing loops at the head and tack are recommended for attaching the sail, as this will allow a tighter furl, and avoid chafe on the furler from a cringle.

Sails for REEFIT B must have the UV strip on the Starboard side.

A good reefing sail will have a relatively high clew to reduce the need to adjust the sheet lead position as you reduce sail. Talk this over with your sailmaker. To prevent any possibility of halyard wrapping, it is essential that the halyard swivel always hoists to its predetermined position at the head of the foil, regardless of the luff length of the sail. To ensure this, any shorter luffed cruising sails in your wardrobe, **must have a stop permanently attached to make them up to length**. If you have purchased the *racing option* furler, pennants are not required with racing sails as they are hoisted with conventional halyards, not with the swivel unit.

Sailtrack dimensions - Reefit B

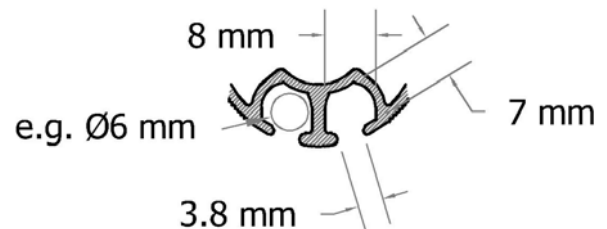

Sail knock-back measurements for REEFIT B furling sails

HEAD

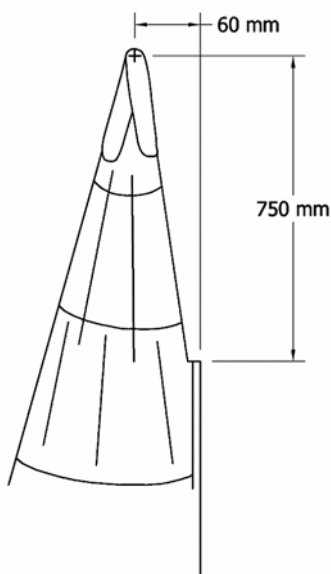

TACK

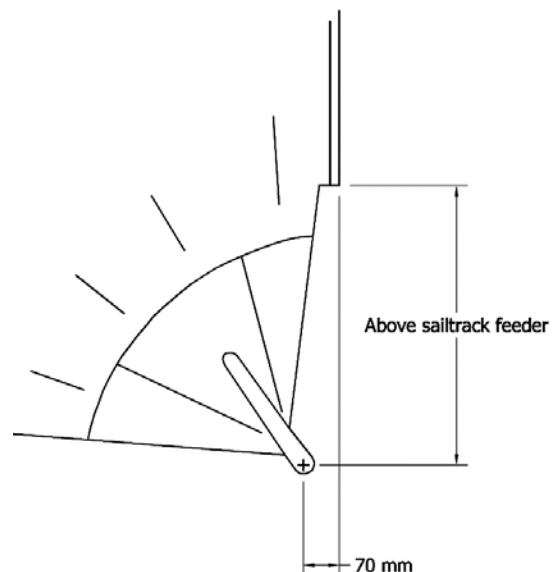

Troubleshooting

PROBLEM	POSSIBLE CAUSES	SOLUTIONS
Sail will not furl or is difficult to furl completely.	Jib halyard is wrapping around forestay because angle between mast and halyard is too shallow.	Check halyard deflector block position. Check to see that the deflector has not come away, and that the correct halyard is in use.
	Jib halyard is wrapping around the forestay because halyard swivel is too low.	See installation instructions regarding swivel height, use a luff strop to raise the swivel to the correct height, near the deflector block.
	Jib halyard is overly tight.	Ease the jib halyard. Mark halyard for full hoist position.
	Spare halyard is wrapping in sail as it furls.	Secure spare halyards away from furler, on rail or behind spreaders.
	Furling line tangled in drum.	Use a ratchet block as last block in the furling line lead, to provide some friction when unfurling.
	Sail full of wind when furling.	Luff the sail more before trying to furl.
	Sail is flogging too much.	Ease a little sheet, then furl, and then repeat.
	Genoa sheets are still cleated.	Free sheets from cleat or winch.
	Insufficient furling line on drum.	Remove sheets. Rotate furler by hand, wrapping some line back on the drum.
	Rope guide has come loose.	Re position guide and re-tighten rope guide grub screws.
Sail will not unfurl or will not unfurl completely.	Jib halyard is wrapping around forestay because angle between mast and halyard is too shallow.	Check halyard deflector block position. Check to see that the deflector has not come away, and that correct halyard is in use.
	Jib halyard is wrapping around the forestay because halyard swivel is too low.	See installation instructions regarding swivel height, use a luff strop to raise the swivel to the correct height, near the deflector block.
	Jib halyard is overly tight.	Ease the jib halyard. Mark halyard for full hoist position.
	Spare halyard is wrapping in sail as it furls.	Secure spare halyards away from furler, on rail or behind spreaders.
	Furling line is not free.	Free furling line, or eliminate friction.
	Too much line on the drum.	Adjust the amount of line on the drum and or change the position of the forward lead block to allow line to roll evenly onto drum.
Sail does not stay furled.	Sail not furled tightly on foil.	Maintain sufficient weight on sheets when furling.
	Furling line not secure.	Secure furling line.
Sail will not go up.	Boltrope or luff tape won't go in groove.	Check luff tape for fraying or check size.
	Sail catching in feeder.	Flake sail more loosely on deck.
	Dirt in groove.	Clean groove.
Sail will not raise completely or luff will not come tight.	Halyard swivel is hitting shroud spinner.	Luff of sail or strop is too long and must be shortened.
	Halyard swivel off foil.	Luff of sail is too long or foil is too short. Follow installation instructions.
	Angle between halyard and mast is too sharp and halyard is pulling aft too much.	Halyard must be pulling from a higher point on the mast. The deflector block should be moved up or the sail must be shortened.
Sail will not come down.	Halyard swivel off top of foil.	Luff of sail is too long or foil is too short. Follow installation instructions.
	Halyard is wrapping on the forestay.	Angle between the forestay and halyard is too shallow, or swivel too low. Refer to installation instructions to correct.
U.V strip rolls up inside sail.	Furling line is wrapped on drum the wrong way.	Re run furling line so it goes on when turning furler in a clockwise rotation.
	UV strip is on the wrong side of the sail	Fit UV strip to starboard side of sail.
Line jams between guard and plates.	Line not lead through window in stainless steel guard.	Rotate guard to desired angle and run furling line through window in guard.
Furler rotates in jerks or stay sags	Insufficient tension on forestay.	Tighten forestay and / or backstay to eliminate sag.
	Furling line knot touching arms under drum.	Tie a small knot (simple stopper knot) only or remove 300mm of rope core.

Race Pack Option Information

The racing option is only available as a factory option with your original order. Unless you specifically ordered it, it will not be installed on your furler.

Use of the factory *Racing Option*.

When the *racing option* unit is used as a headfoil for racing, allow the halyard swivel to drop down below the sailtrack entry feeder, and rest on top of the torque tube, as it is not used to hoist sails in a racing situation.

The tack of the sail is attached at a convenient position on the bow chainplate.

Both sail feeders should be in place for racing.

Racing sails to be used with the Reefit system need to be cut with sufficient “knock back” at the tack to clear the halyard swivel and furler bottom end and must have the bolt rope extending all the way to the head of the sail, but short at the tack so it is not in either feeder when the sail is up. These measurements are best taken on the boat as they can vary with different installations.

Stripping the unit.

Remove your cruising sail and pull the furling line off the drum. You will need to untie the stopper knot in the furling line and remove it completely. This will allow the rope guide to be separated and removed after undoing the 2 fasteners that clamp it together. Use a screwdriver to remove the 4 fasteners from the joint line in the top drum plate, separate the halves and remove. **(Image 21)** This will allow access to the fasteners in the bottom drum plate, so it too can be separated and removed. **(Image 22)** Ensure the top swivel unit is at the bottom of the furler below the sailtrack entry feeder as described above. (You may find it useful to use electrical or gaffa tape to hold it down and out of the way while racing)



Reassembly is a reversal of this procedure, ensuring that the furling line again passes through the entry bars in the rope guide, Ensure that the guide is correctly orientated when refastened, and that the drum plates don't touch the guard when the furler spins. Then the furling line is spooled on neatly and firmly while the drum is turned clockwise **prior** to re hoisting the cruising sail. Make sure that the top swivel unit is back above the sail entry feeder before hoisting the sail.

Parts List

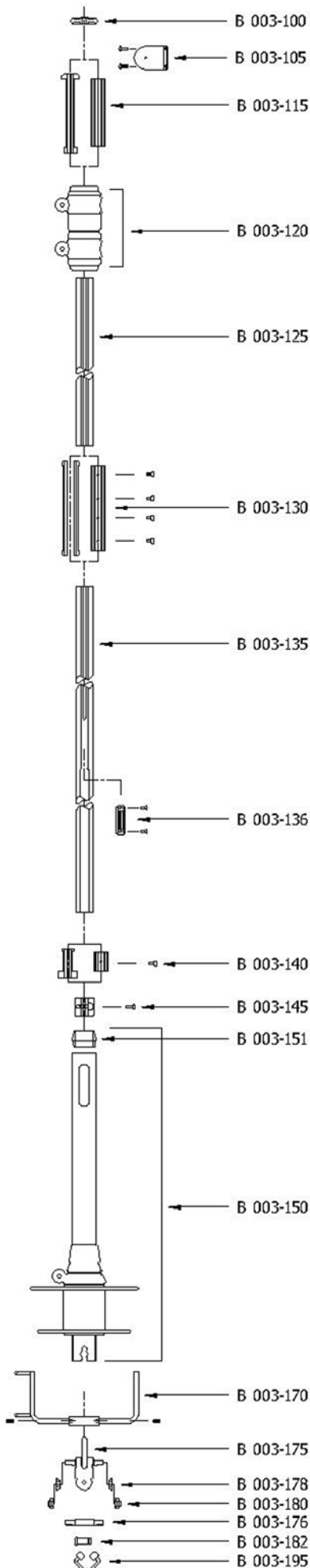

20 years of experience has shown that there is very rarely a need to dismantle the internal components for service of ball races etc. If you do need to tackle this level of service or repair, please consider shipping the relevant sub-assembly to us for refurbishment, or contact us for detailed step-by-step service instructions and parts diagrams.

The diagram indicates the parts that are easily user-replaceable. Contact us directly for supply of any parts.

Part #	Description
B 003-100	Shroud spinner (2 parts)
B 003-105	Halyard deflector block (includes 4 fasteners)
B 003-115	Top bearing assembly (bush and carrier)
B 003-120	Top swivel unit - complete
B 003-125	Anodised 2m foil extrusion
B 003-130	Joint bearing assembly (bush, carrier, fasteners)
B 003-135	Anodised 2m Sail entry foil extrusion
B 003-136	Sailtrack entry feeder with fasteners
B 003-140	Bottom bearing assembly & fastener
B 003-145	Bottom clamp and fasteners x 2
B 003-150	Drum, tack swivel, torque tube sub-assembly
B 003-151	Torque tube cap only (nylon)
B 003-170	Stainless steel Rope Guide & fasteners
B 003-175	Standard forestay link and toggle
B 003-176	Base pin 12.7mm, 10mm threads
B 003-178	Collets x 2
B 003-180	M10 nyloc nut x 2
B 003-182	Standard 1/2" Clevis pin (with split pin)
B 003-195	Sail feeder with tie line
Part # Race pack option parts	
B 003-210	Racing option Top drum plate & fasteners
B 003-215	Racing option Bottom drum plate & fasteners
B 003-220	Racing option Rope guide with fasteners
B 003-250	Racing Option drum etc sub-assembly

Almasts Australia P/L
 6 West Tamar Rd
 Launceston 7250 Tasmania Australia.
 Phone +61 3 6331 3171
 Email info@almasts.com.au
 Web www.almasts.com.au

Warranty and Contact Details

We are sure you will find your Reefit furler useful and enjoyable for many years. Reefit has a ten-year warranty. Complete warranty conditions are stated below. You should fill out the enclosed register coupon and return it to Almasts.

Warranty for Reefit B

- A Almasts will repair or replace any of the goods or parts thereof in respect of which any defects arise solely from faulty construction, material or workmanship.
- B Almasts shall only be responsible for defects which appear on Reefit jib furling and reefing system within a period of ten years from the day of delivery to the customer, provided always that any defects are notified to Almasts in writing 14 days from the day of discovery or from the day when the defect should have been discovered.
- C Almasts shall not be responsible for defects arising from any material provided by the buyer or by any construction stipulated by him.
- D Almasts' responsibilities set out above shall only apply in the event that the Reefit jib furling and reefing system has been installed and maintained according to the owner's manual and used under load conditions within the recommendations published in promotional materials.
- E The buyer shall notify Almasts of any defects or faults in the goods within 14 days of the date when the defects became apparent.
- F If the goods delivered from Almasts prove to be defective, Almasts is entitled at its own choice to repair or to replace the goods.
- G Repairs by anyone other than authorised representatives shall void this warranty unless it accords with Almasts' guidelines and standard of workmanship.
- H Defective goods shall always be promptly returned to Almasts Australia in Tasmania.
- I The undertakings contained in clauses A to H inclusive above are given in lieu of and to the exclusion of all conditions, warranties and representations whether express or implied by statute or otherwise as to the quality of the goods or their fitness for any particular purpose or otherwise and Almasts shall bear no liability in respect of the goods save as provided in the said clauses above.
- J This warranty gives you specific legal rights, and you may also have other legal rights which vary from country to country.
- K For further information contact the manufacturer at Almasts Australia Pty Ltd
6 West Tamar Rd, Launceston, Tasmania, Australia, 7250
Ph: (international) +61 3 6331 3171; (within Australia) (03) 6331 3171
Email: info@almasts.com.au
www.almasts.com.au



WARRANTY REGISTRATION

To be filled out and returned to Almasts Australia Pty Ltd, 6 West Tamar Rd, Launceston, Tas, 7250
Fax: (03) 6334 6070, Email info@almasts.com.au

Model: **Reefit B**

Forestay diameter: _____ Date of purchase: _____

Place of purchase: _____

Type of boat _____

Customer's Name _____

Customer's Address _____

Phone _____ Email _____